

made of grade 304 stainless steel - grade 316 on request

Modular channels with grating: see page 30 for accessories,  
page 17 for gullies, pages 27 and 28 for flange for waterproof membrane application.

### Dwg. 0901: CHANNELS WITH GRATING

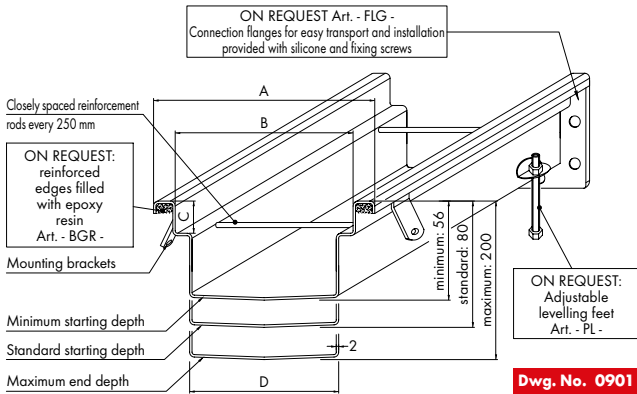

Dwg. No. 0901

\* = these values depend on the type of grating

Article	DIMENSIONS in mm			
S= mm 2	A	B	C	D
STANDARD	100	67	26*	60
CGS 100 25 (see note **)	100	67	26*	60
CGS 150 25	150	104	26*	70
CGS 200 25	200	154	26*	120
CGS 225 25	225	190	26*	160
CGS 250 25	250	204	26*	170
CGS 300 25	300	254	26*	220
CGS 350 25	350	304	26*	270
CGS 400 25	400	354	26*	320
CGS 450 25	450	404	26*	370
CGS 500 25	500	454	26*	420

\*\* = Inoxsystem Total hygienic channel (see page 48) but with standard grating mesh 25x22 h 25 mm

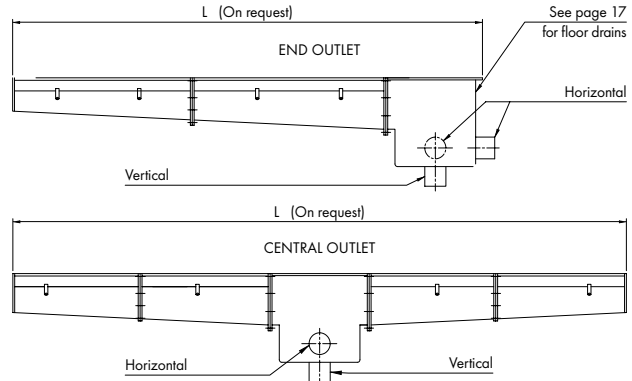

### N.B.

- Built-in slope 4 mm/m.
- Closely spaced reinforcement rods.
- Mounting brackets.
- On request: connection flanges (every 3 or 6 m) for easy transport and installation (Art. - FLG -) see catalogue page 30.
- On request: reinforced edges filled with epoxy resin (Art. - BGR -) see catalogue page 3 and 30.
- On request: adjustable levelling feet (Art. - PLG -) see catalogue page 30.
- On request: 1/2" inlet socket to let water flush and clean the drain (Art. - IL -).

1e - Closed grating with double slot

1d - Heavy duty ladder grating

1c - Heelsafe

1b - Antislip

1a - Standard

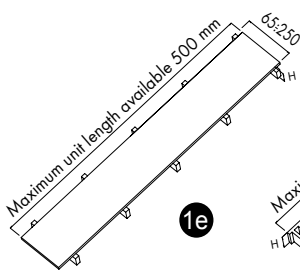

Dwg. No. 0855

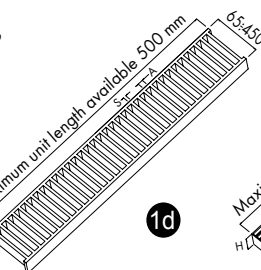

Dwg. No. 0851

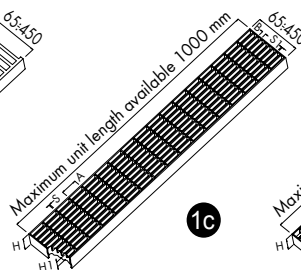

Dwg. No. 0854

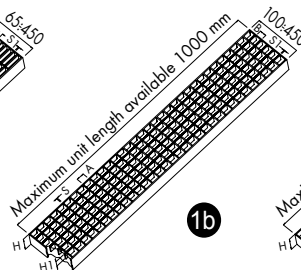

Dwg. No. 0858

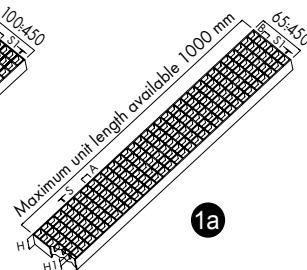

Dwg. No. 0853

Plate thk	Bearing bar	Slot	H
6 mm	20x8	10 mm	25

Edge bar	Bearing bar HxS	Clear opening A	H
25x8	25x8	20	25

Mesh AxB	Bearing bar HxS	Cross bar H1X51
50x11 (Antiatcco)	25x2	10x2

Mesh AxB	Bearing bar HxS	Cross bar H1X51
25x22 (Std)	25x2	10x2

Mesh AxB	Bearing bar HxS	Cross bar H1X51
25x22 (Std)	25x2	10x2

### INSTALLATION EXAMPLES

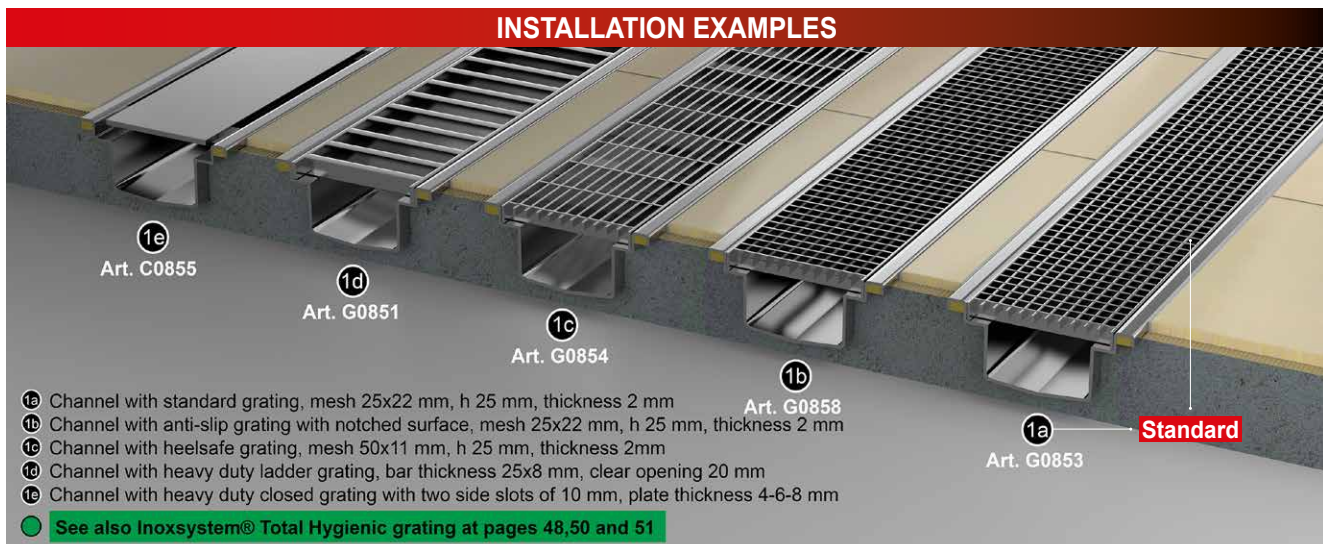

- 1a Channel with standard grating, mesh 25x22 mm, h 25 mm, thickness 2 mm Art. G0858
- 1b Channel with anti-slip grating with notched surface, mesh 25x22 mm, h 25 mm, thickness 2 mm
- 1c Channel with heelsafe grating, mesh 50x11 mm, h 25 mm, thickness 2mm
- 1d Channel with heavy duty ladder grating, bar thickness 25x8 mm, clear opening 20 mm
- 1e Channel with heavy duty closed grating with two side slots of 10 mm, plate thickness 4-6-8 mm

See also Inoxsystem® Total Hygienic grating at pages 48,50 and 51

Dimensions can be modified on request.

These technical drawings are property of INOXSYSTEM® and cannot be copied or reproduced without our prior written permission.